

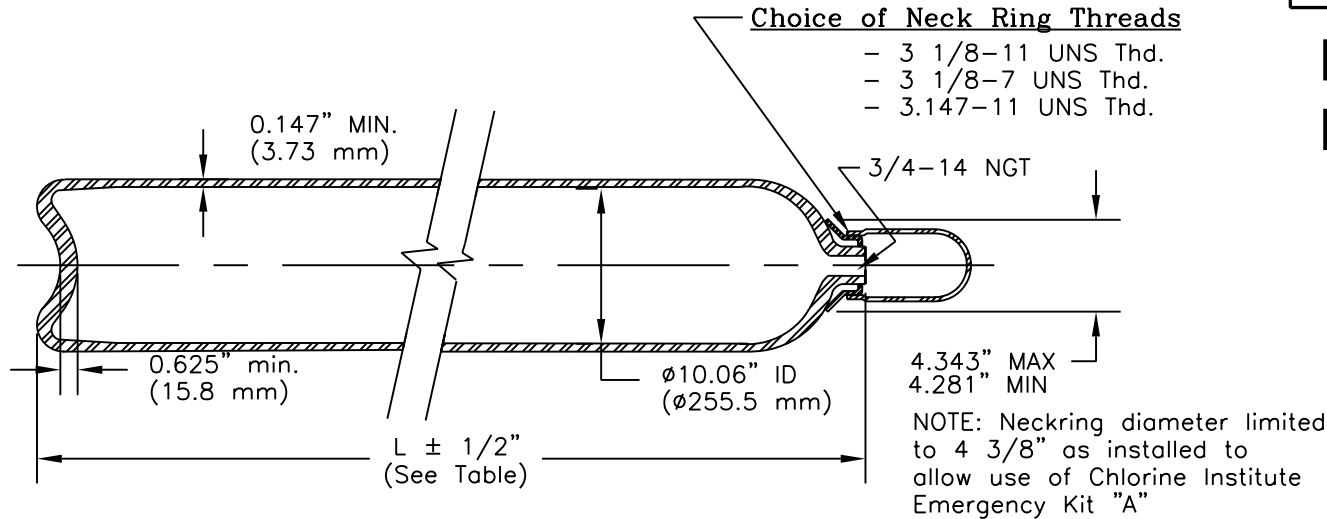

REV.	ECN - DESCRIPT.	DATE	DRWN.	CHKD.	APP.
01	1247	3/27/95			

DRAWING FOR REFERENCE ONLY



CYLINDER MODEL	CYLINDER LENGTH "L" in (mm)	MINIMUM WATER CAPACITY in ³ (liter)	APPROXIMATE CYLINDER WEIGHT lbs (kg)
10CL100	34 (864)	2225 (36.4)	80 (36.3)
10CL150	48 (1219)	3328 (54.4)	105 (47.6)

SPECIFICATION: DOT 3AA 480		3. Manufacture: Hot billet pierced followed by hot drawing.
1. Principal Elements: - Service pressure: 480 psi (33.1 bar) - Test pressure: 800 psi (55.2 bar)	4. Heat Treatment: Q & T	
	5. Norris Standard Mechanical Properties: - Tensile: $\geq 105,000$ psi - Elong.: $\geq 20\%$ (on 2" gauge) - Flattening: to 6xt without cracks	
2. Material: Chrome-Moly steel, (A.I.S.I. 4130X)		
D.O.T. Wall Stress Calculations: $S = P(1.3D^2 + 0.4d^2)/(D^2 - d^2)$		
S = Maximum wall stress, psi P = Test pressure, psi D = Outside diameter, inch d = Inside diameter, inch	$s = \frac{800 [1.3 (10.354)^2 + 0.4 (10.06)^2]}{(10.354)^2 - (10.06)^2}$	
	s = 23,973 psi (165.3 MPa)	

 NORRIS CYLINDER COMPANY P.O. BOX 7486 LONGVIEW, TEXAS 75607			
SEAMLESS STEEL CHLORINE CYLINDERS			
SCALE	NOT TO SCALE	DRAWING NO.	REV.
DWN. BY	M.Benham	2/26/92	901A-B-9142 01
CHK'D BY	R.Shafkey	2/26/92	
APP'D BY	B.Arnold	2/26/92	SHEET NO. 1 OF 1 SHEETS