

**WARREN  
RUPP**A unit of  
**IDEX**  
IDEX CORPORATION

What's New | Trade Show Schedule

**SandPIPER** SandPIPER II

- [Company Profile](#)
- [Product Lines](#)
- [Technical Info](#)
- [Literature](#)
- [Distributors](#)
- [Downloads](#)
- [Request More Info](#)

[<<Back to Products](#)[www.minhchauvn.com](http://www.minhchauvn.com)**S05 Non-Metallic**

For a pump that can pass the acid test, consider the new Sandpiper® S Nonmetallic Pump Series. Rugged, all bolted construction. No clamps. Models in PVDF, Nylon, Conductive Acetal and Polypropylene. Specially-coated, chemically-resistant hardware.

[Datasheet](#) | [Service Manual](#) | [Performance Curves Gal](#) | [Performance Curves Ltr](#)

**Pump Specifications**

<b>Pipe Size:</b>	.5" / 15mm
<b>Displacement Per Stroke:</b>	.026 gal / .098 ltr
<b>Max. Flow per Minute:</b>	14 gal / 52 ltr
<b>Max. Solids Handling:</b>	.125" / 3mm
<b>Max. Discharge Pressure:</b>	100 PSI / 6.9 BAR

**Warren Rupp, Inc.**

A Unit of IDEX Corporation  
800 North Main Street  
P.O. Box 1568  
Mansfield, Ohio 44901-1568  
USA

If you have any problems using our site, please contact the [Webmaster](#).  
All contents ©2002, Warren Rupp, Inc. All rights reserved.

**WARREN  
RUPP®**

Quality System  
ISO9001 Certified

Environmental  
Management System  
ISO14001 Certified

**IDEX**  
IDEX CORPORATION

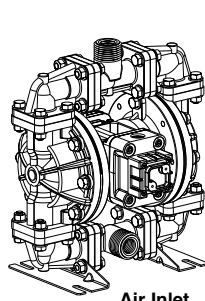

Air Inlet  
Side View

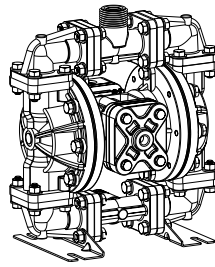

Air Exhaust  
Side View

U.S. Patent #5,996,627; 6,241,487  
Other U.S. Patents Applied for



# SandPIPER II®

## S05 Non-Metallic Design Level 2 Ball Valve

Air-Powered  
Double-Diaphragm Pump

ENGINEERING, PERFORMANCE  
& CONSTRUCTION DATA

INTAKE/DISCHARGE PIPE SIZE	CAPACITY	AIR VALVE	SOLIDS-HANDLING	HEADS UP TO	DISPLACEMENT/STROKE
½" NPT (internal) or ½" BSPT (Tapered) 1" NPT (external) or 1" BSPT (Tapered)	0 to 14 gallons per minute (0 to 52 liters per minute)	No-lube, no-stall design	Up to .125 in. (3mm)	100 psi or 231 ft. of water (7 Kg/cm <sup>2</sup> or 70 meters)	.026 Gallon / .098 liter

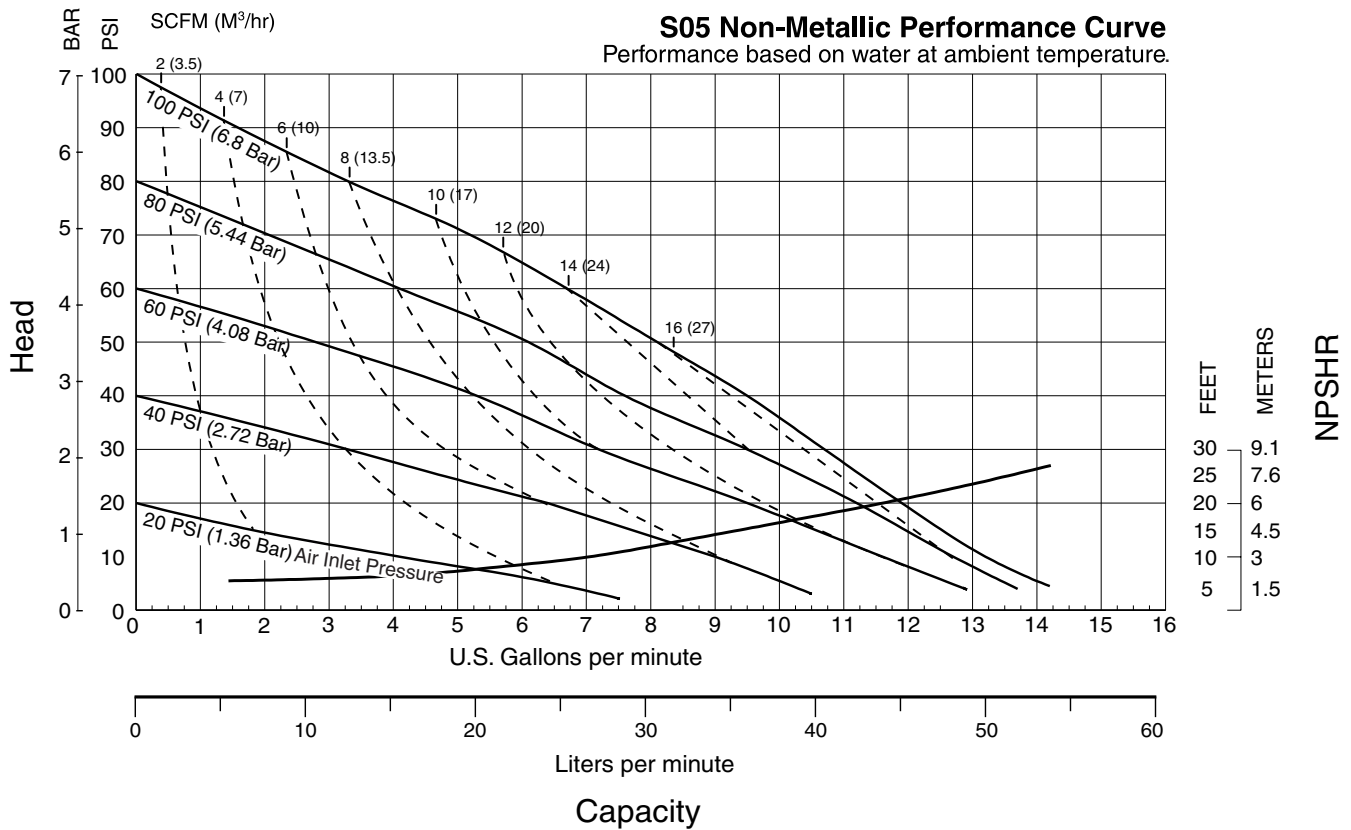

SandPIPER II® pumps are designed to be powered only by compressed air.

# Explanation of Pump Nomenclature

## S05 Non-Metallic · Design Level 2· Ball Valve

MODEL	Pump Brand	Pump Size	Check Valve Type	Design Level	Wetted Material	Diaphragm/Check Valve Materials	Check Valve Seat	Non-Wetted Material Options	Porting Options	Pump Style	Pump Options	Shipping Kit Options	Weight lbs. (kg)
S05B2P1TPNS000.	S	05	B	2	P	1	T	P	N	S	0	00.	16 (8)
S05B2P2TPNS000.	S	05	B	2	P	2	T	P	N	S	0	00.	16 (8)
S05B2PUTPNS000.	S	05	B	2	P	U	T	P	N	S	0	00.	16 (8)
S05B2K1TPNS000.	S	05	B	2	K	1	T	P	N	S	0	00.	18 (9)
S05B2K2TPNS000.	S	05	B	2	K	2	T	P	N	S	0	00.	18 (9)
S05B2KUTPNS000.	S	05	B	2	K	U	T	P	N	S	0	00.	18 (9)
S05B2N1TPNS000.	S	05	B	2	N	1	T	P	N	S	0	00.	16 (8)
S05B2N2TPNS000.	S	05	B	2	N	2	T	P	N	S	0	00.	16 (8)
S05B2NUTPNS000.	S	05	B	2	N	U	T	P	N	S	0	00.	16 (8)
S05B2G1TXNS000.	S	05	B	2	G	1	T	X	N	S	0	00.	17 (8)
S05B2G2TXNS000.	S	05	B	2	G	2	T	X	N	S	0	00.	17 (8)
S05B2GUTXNS000.	S	05	B	2	G	U	T	X	N	S	0	00.	17 (8)
S05B2P1TPBS000.	S	05	B	2	P	1	T	P	B	S	0	00.	16 (8)
S05B2P2TPBS000.	S	05	B	2	P	2	T	P	B	S	0	00.	16 (8)
S05B2PUTPBS000.	S	05	B	2	P	U	T	P	B	S	0	00.	16 (8)
S05B2K1TPBS000.	S	05	B	2	K	1	T	P	B	S	0	00.	18 (9)
S05B2K2TPBS000.	S	05	B	2	K	2	T	P	B	S	0	00.	18 (9)
S05B2KUTPBS000.	S	05	B	2	K	U	T	P	B	S	0	00.	18 (9)
S05B2N1TPBS000.	S	05	B	2	N	1	T	P	B	S	0	00.	16 (8)
S05B2N2TPBS000.	S	05	B	2	N	2	T	P	B	S	0	00.	16 (8)
S05B2NUTPBS000.	S	05	B	2	N	U	T	P	B	S	0	00.	16 (8)
S05B2G1TXBS000.	S	05	B	2	G	1	T	X	B	S	0	00.	17 (8)
S05B2G2TXBS000.	S	05	B	2	G	2	T	X	B	S	0	00.	17 (8)
S05B2GUTXBS000.	S	05	B	2	G	U	T	X	B	S	0	00.	17 (8)

### Pump Brand

S=SandPIPER II®

### Pump Size

05=½"

### Check Valve Type

B= Ball

### Design Level

2= Design Level

### Wetted Material

K= PVDF

G=Conductive Acetal

N= Nylon

P= Polypropylene

### Diaphragm Check Valve Materials

1= Santoprene/Santoprene

2= Virgin PTFE/Santoprene

Backup/Virgin PTFE

B= Buna N

U= Polyurethane/Polyurethane

### Check Valve Seat

T= Virgin PTFE

### Non-Wetted Material Options

P= Polypropylene

1= Polypropylene with PTFE

Coated Hardware

C=Conductive Acetal

### Porting Options

N=NPT Threads

B= BSPT Threads (Tapered)

1= Dual Porting (NPT)

2= Top Dual Porting (NPT)

3= Bottom Dual Porting (NPT)

4= Dual Porting (BSPT) (Tapered)

5= Top Dual Porting (BSPT) (Tapered)

6= Bottom Dual Porting (BSPT) (Tapered)

### Pump Style

S= Standard

### Pump Options

0= None

1= 3M Muffler

### Kit Options

00.=None

P0.=0-30VDC Pulse Output Kit

P1.=Intrinsically-Safe 10-30VDC Pulse Output Kit

P2.=110/120 or 220/240VAC Pulse Output Kit

P3.=Intrinsically-Safe 110/120VAC Pulse Output Kit

P4.=Intrinsically-Safe 220/240VAC Pulse Output Kit

E0.=Solenoid Kit with 24VDC Coil

E1.=Solenoid Kit with 24VDC Explosion-Proof Coil

E2.=Solenoid Kit with 24VDC/12VDC Coil

E3.=Solenoid Kit with 24VDC/12VDC Explosion-Proof Coil

E4.=Solenoid Kit with 110VAC Coil

E5.=Solenoid Kit with 110VAC Explosion-Proof Coil

E6.=Solenoid Kit with 220VAC Coil

E7.=Solenoid Kit with 220VAC Explosion-Proof Coil

SP.=Stroke Indicator Pins



**CAUTION! Operating temperature limitations are as follows:**

Materials	Operating Temperatures		
	Maximum*	Minimum*	Optimum**
<b>Buna</b> General purpose, oil-resistant. Shows good solvent, oil, water and hydraulic fluid resistance. Should not be used with highly polar solvents like acetone and MEK, ozone, chlorinated hydrocarbons and nitro hydrocarbons.	190°F 88°C	-10°F -23°C	0°F to 140°F 10°C to 60°C
<b>Polyurethane</b> High tensile material with excellent abrasion resistance. A general purpose material with excellent resistance to most oils.	210°F 99°C	-40°F -40°C	-40°F to 210°F -40°C to 99°C
<b>PVDF</b>	200°F 93°C	10°F -13°C	
<b>Santoprene®</b> Injection molded thermoplastic elastomer with no fabric layer. Long mechanical flex life. Excellent abrasion resistance.	212°F 100°C	-10°F -23°C	50°F to 212°F 10°C to 100°C
<b>Virgin PTFE</b> Chemically inert, virtually impervious. Very few chemicals are known to react chemically with PTFE: molten alkali metals, turbulent liquid or gaseous fluorine and a few fluoro-chemicals such as chlorine trifluoride or oxygen difluoride which readily liberate free fluorine at elevated temperatures.	212°F 100°C	-35°F -37°C	50°F to 212°F 10°C to 100°C
<b>Nylon</b>	120°F 48°C	32°F 0°C	
<b>Conductive Acetal</b>	180°F 82°C	-10°F -23°C	
<b>Polypropylene</b>	150°F 65°C	40°F 5°C	

For specific applications, always consult "Chemical Resistance Chart" Technical Bulletin

\*Definite reduction in service life.

\*\*Minimal reduction in service life at ends of range.

# Dimensions: S05 Non-Metallic

Dimensions in Inches  
Dimensional Tolerance:  $\pm 1/8"$

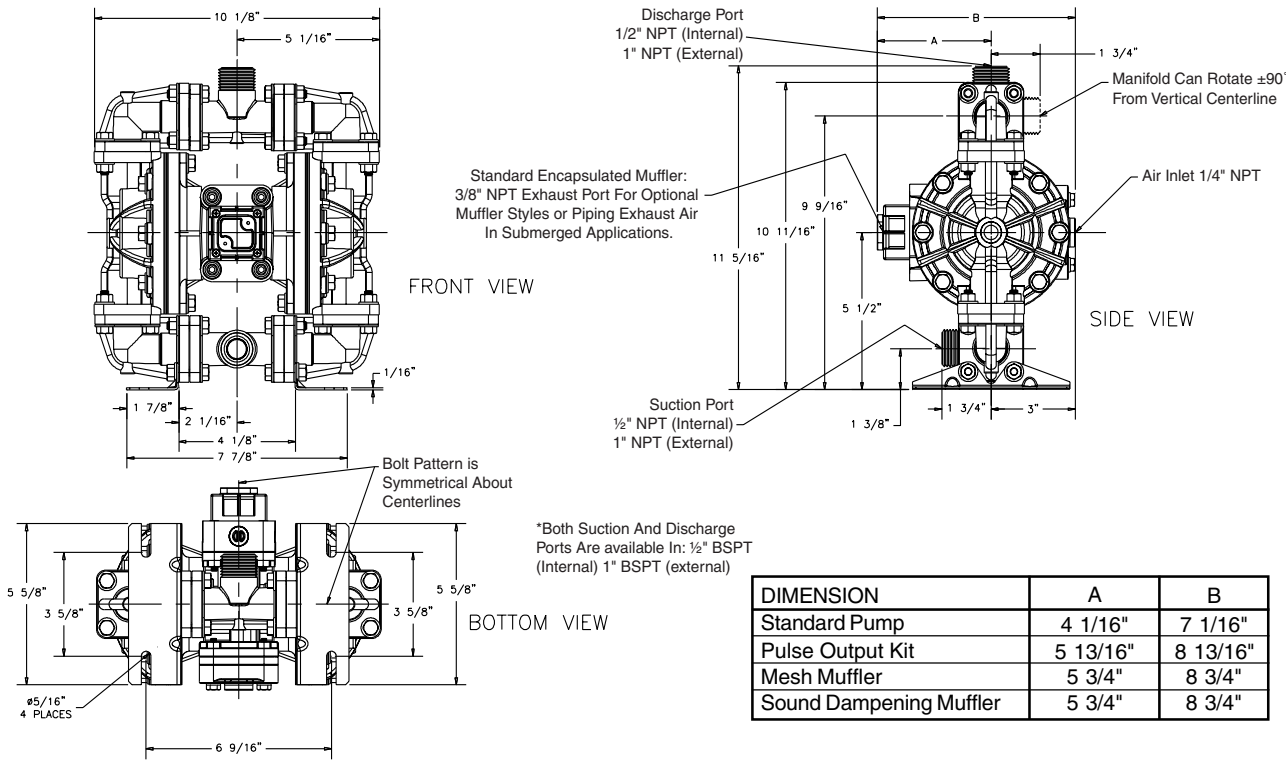

Dimensions in Millimeters  
Dimensional Tolerance:  $\pm 3\text{mm}$

